

Fig. 102 / 220 PN16



Robinet à soupape

- Fonte EN GJL-250
- A soufflet
- Contacts inox
- Pour les agents non-agressifs

Globe valve

- Cast iron EN GJL-250
- With bellow
- Stainless steel seats
- For non-aggressive medium

Absperrventil

- Grauguss EN GJL-250
- Mit Faltenbalg
- Niro dichtend
- Für nicht aggressive Flüssigkeiten

Dimensions entre brides selon DIN EN 558-1, série 1
Face to face dimensions according to DIN EN 558-1, series 1
Baulänge nach DIN EN 558-1, Grundreihe 1

DN	L	D	D ₁	D ₀	d	n	f	g	H	h	Poids
											Weight
											Gewicht
mm											kg
15	130	95	45	65	14	4	2	14	159	5	3,2
20	150	105	56	75	14	4	2	16	159	5	3,9
25	160	115	65	85	14	4	2	16	169	7	4,6
32	180	140	76	100	19	4	2	18	176	8	6,3
40	200	150	84	110	19	4	3	18	208	10	9,0
50	230	165	99	125	19	4	3	20	225	13	12,3
65	290	185	118	145	19	4	3	20	245	16	16,3
80	310	200	132	160	19	8	3	22	294	20	22,4
100	350	220	156	180	19	8	3	24	330	25	34,0
125	400	250	184	210	19	8	3	26	334	32	50,0
150	480	285	211	240	23	8	3	26	432	40	74,0
200	600	340	266	295	23	12	3	28	515	50	130,5
250	730	405	319	355	28	12	3	32	645	63	210

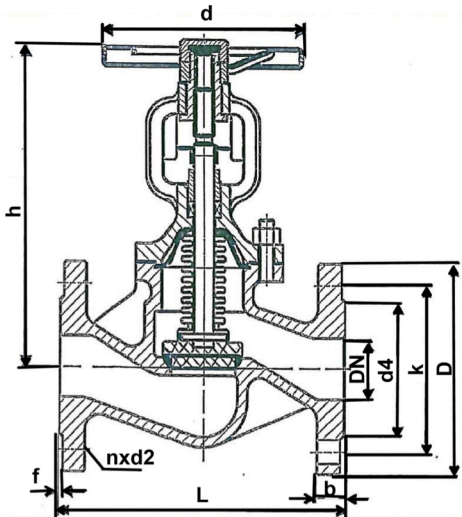

Conditions de service / Working conditions / Betriebsdruck und Temperatur

Température (°C)	-10	20	100	150	200	250	300
Pression / Pressure / Druck (bar)	16	16	16	14,4	12,8	11,2	9,6

Matières / Materials / Material

- Corps :** EN GJL-250
- Chapeau :** EN GJL-250
- Volant :** EN GJL-250
- Clapet :** X20 CR 13
- Tige :** X20 CR 13
- Soufflet :** Inox (X6 CR NI MO Ti -17-12-2)
- Etanchéité de tige :** Graphite
- Etanchéité de sièges :** X20 CR13

- Body :** EN GJL-250
- Bonnet :** EN GJL-250
- Handwheel :** EN GJL-250
- Disc :** X20 CR 13
- Stem :** X20 CR 13 Stainless steel
- Bellow :** X6 CR NI MO Ti -17-12-2)
- Gland packing :** Graphite
- Seats :** X20 CR13

- Gehäuse :** EN GJL-250
- Deckel :** EN GJL-250
- Handrad :** EN GJL-250
- Kegel :** X20 CR 13
- Spindel :** X20 CR 13
- Faltenbalg :** (X6 CR NI MO Ti -17-12-2)
- Packung :** Graphit
- Sitzring :** X20 CR 13

04-2013



ROBINETTERIE INDUSTRIELLE
 30 rue Henri Durre - 59590 RAISMES
 Tél. 33 (0)3 27 36 70 12 - Fax 33 (0)3 27 36 75 20

CE PED 97/23



www.stemat-jansen.fr

Document non contractuel