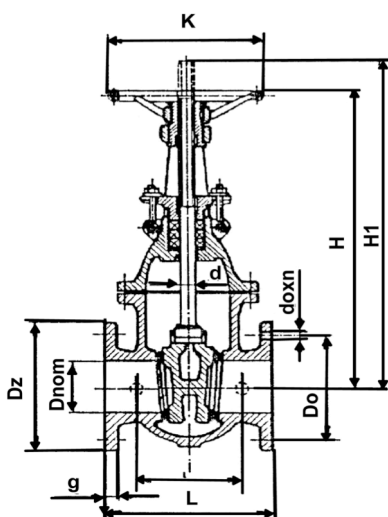

**Fig. 032 / 75 PN25**



**Vanne à passage direct**

- Corps ovale en acier
- Tige montante
- Contacts Inox
- Pour les eaux, vapeur, fluide thermique, agents non-agressifs

**Oval Body Gate valve**

- Cast steel
- Outside stem
- Seats in Stainless steel
- For water, steam and non-aggressive medium

**Keilovalschieber**

- Stahlguss
- Aussen Spindel
- Niro dichtend
- Für wasser, Dampf und nicht aggressive Flüssigkeiten

**Dimensions entre brides selon EN 558-1 serie 15**

Length according to EN 558-1 series 15

Baulänge nach EN 558-1 Grundreihe 15

DN	L	Dz	Do	do	g	Nbre de trous	H	H <sub>1</sub>	k	Poids
										Weight
										Gewicht
										kg
40	240	150	110	18	18	4	300	357	225	22
50	250	165	125	18	20	4	325	387	225	27
65	270	185	145	18	22	8	380	463	280	37
80	280	200	160	18	24	8	420	520	280	45
100	300	235	190	22	24	8	487	604	280	58
125	325	270	220	26	26	8	574	720	320	86
150	350	300	250	26	28	8	652	827	320	110
200	400	360	310	26	30	12	817	1035	360	178
250	450	425	370	30	32	12	958	1233	500	257
300	500	485	430	30	34	16	1107	1435	640	362
350	550	555	490	33	38	16	1270	1650	640	508
400	600	620	550	36	40	16	1415	1845	720	693
500	700	730	660	36	44	20	1790	2330	800	1151
600	800	845	770	39	46	20	2105	2745	800	1798

**Conditions de service**

Working conditions

Betriebsdruck und Temperatur

Température (°C)	100	150	200	250	300	350	400
Pression / Pressure / Druck (bar)	25	21,6	19,6	17,2	14,7	13,2	12,3

**Matières / Materials / Material**

**Corps :** GSC25N/GP240GH/1.0619N  
**Chapeau :** GSC25N/GP240GH/1.0619N  
**Opercule :** GSC25N/GP240GH/1.0619N  
**Volant :** EN GJS-400  
**Tige :** X20 CR13  
**Etanchéité de tige :** Graphite  
**Etanchéité des sièges :** X20 CR13  
**Etanchéité corps/chapeau :** Graphite

**Body :** GSC25N/GP240GH/1.0619N  
**Bonnet :** GSC25N/GP240GH/1.0619N  
**Wedge :** GSC25N/GP240GH/1.0619N  
**Hand wheel :** EN GJS-400  
**Stem :** X20 CR13  
**Gland packing :** Graphite  
**Seats :** X20 CR13  
**Gasket body/bonnet :** Graphite

**Gehäuse :** GSC25N/GP240GH/1.0619N  
**Deckel :** GSC25N/GP240GH/1.0619N  
**Keil :** GSC25N/GP240GH/1.0619N  
**Handrad :** EN GJS-400  
**Spindel :** X20 CR13  
**Packung :** Graphit  
**Sitzring :** X20 CR13  
**Dichtung :** Graphit

04-2013